

Nimbus Unicycles

What should be in your box

- Saddle (1) with Seatpost (2)
- Seatpost Clamp (3)
- Frame (4)
- Wheel (5) with Cranks (6)
- Pedals (7)
- Bearing Clamps - x2 (8)
- Bolts and Washers - x4 (9)
- Allen Key & Spanner

You are going to need a bicycle pump (Schrader Valve).

Your unicycle comes in kit form and should only take 15 minutes to assemble. Firstly determine that you have all the components listed, if you are short contact your supplier immediately.

How To build your Unicycle

- Take the frame (4) and slip the quick release and collar (3) (or double bolt clamp depending on model) over the frame. The slot in the frame should line up with the slot in the clamp this is the back of your unicycle. If your unicycle has a quick release clamp the lever should be on the right hand side.
- Insert the Seatpost (2) in to the frame (4) and tighten up the clamp. Tighten both bolts evenly if you can alternate from the top to the bottom until both are tight and the seatpost does not twist. If your unicycle has a quick release you tighten it by turning the nut on the other side to the lever. Do not try to swivel the handle as this will damage the clamp.
- Fit the wheel (8) into the frame; be sure you have the right hand crank (6) on the right hand side of the unicycle when it is facing forward
- Installing using the allen bolts ensure that each bolt is tightened evenly and that the flat parts of the bearing holders are parallel. Tighten with a 5mm allen key. Do not over tighten, the wheel should spin easily, if it does not, slacken the bolts slightly.
- Fit the pedals (7) onto their correct cranks (6) by matching the letter on the cranks with those on the pedals. Tighten firmly using your 15mm spanner (the left hand crank has a reverse thread).
- Pump your tyre up (9), remember you will be putting all your weight on this single wheel, so pump it up more than you would your bike.
- Now set the seat at the right height. When sitting on the unicycle, with your heel on the pedal your leg should be straight. If you cannot get your seat low enough you will need to shorten the seatpost (2). This is best done with a pipe cutter; you can use a hacksaw and file. Remove as little as is needed. Always have at least 5cm of the seatpost in the frame.

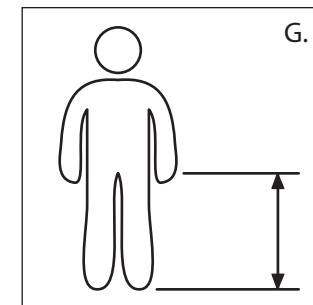
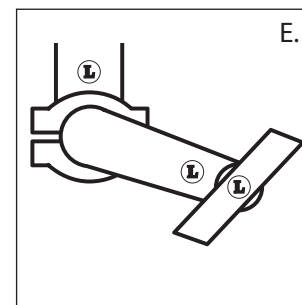
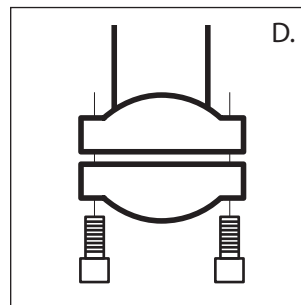
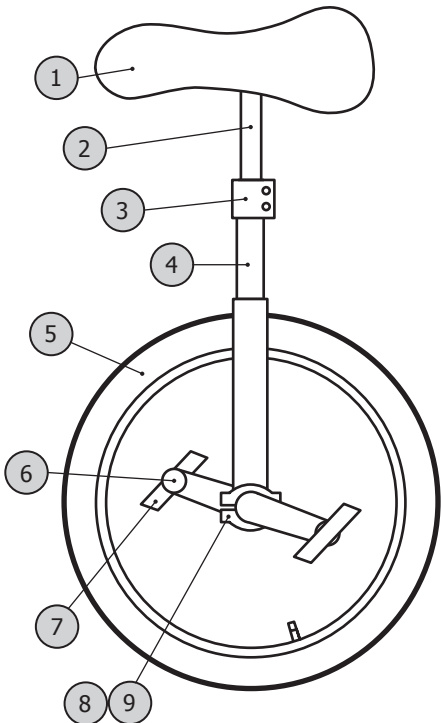

Things that can go wrong

Unicycles are pretty durable but they do need maintaining, here are things to look out for:

- Loose pedals; normally found when riding or by holding the pedal and wiggle it. Tighten immediately! Check that the wheel is fitted in the frame the correct way around. Riding on loose pedals will destroy the cranks.
- Loose cranks; this is normally characterised by a creaking noise. Tighten the axle bolt immediately! If this is left loose it will destroy the crank and hub and to all intent and purpose the unicycle.
- Loose or tight bearing holder bolts; it is most common to find these too tight and the wheel not spinning correctly. Loosen them to free the wheel, after a few minutes of use check that they are still tight enough to stay on.