

# Unicycle.com

## What should be in your box

- Saddle (1) with Seatpost (2)
- Seatpost Clamp (3)
- Frame (4)
- Wheel (5) with Cranks (6)
- Pedals (7)
- Bearing Clamps - x2 (8)
- Bolts and Washers - x4 (9)
- Tools

You are going to need a bicycle pump (Schrader Valve).

Your unicycle comes in kit form and should only take 15 minutes to assemble. Firstly determine that you have all the components listed, if you are short contact your supplier immediately.

## How To build your Unicycle

- Take the frame (4) and slip the double bolt clamp or quick release and collar (3) (dependent on model) over the frame. The slot in the frame should line up with the slot in the clamp this is the back of your unicycle.
- Insert the Seatpost (2) into the frame (4) and tighten up the clamp. Alternate tightening the top and bottom bolts until tight. If you have a quick release set it by holding the lever open then tighten the thumb screw on the opposite side until it is just finger tight. Then close the quick-release lever to lock the seat stem in position. Repeat process until the correct tension is found. If it is too tight it will damage the bolt, if it is too slack it will not hold the seatpost securely.
- Fit the wheel (5) into the frame; be sure you have the right hand crank (6) on the right hand side of the unicycle when it is facing forward
- Fix using the bolts, washers and nuts (see diagram). Be sure that the bolt sits flush and that the tag on the base that fits within the slot in the frame. Tighten with a 10mm spanner. Do not over tighten, the wheel should spin easily, if it does not, slacken the bolts slightly.
- Fit the pedals (7) onto their correct cranks (6) by matching the letter on the cranks with those on the pedals. Tighten firmly using your 15mm spanner (the left hand crank has a reverse thread).
- Pump your tyre up (9), remember you will be putting all your weight on this single wheel, so pump it up more than you would your bike.
- Now set the seat at the right height. When sitting on the unicycle, with your heel on the pedal your leg should be straight. If you cannot get your seat low enough you will need to shorten the seatpost (2). This is best done with a pipe cutter, but you can use a hacksaw and file. Remove as little as is needed. Always have at least 5cm of the seatpost in the frame.

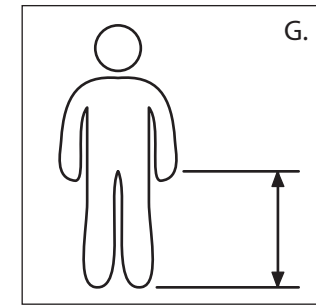
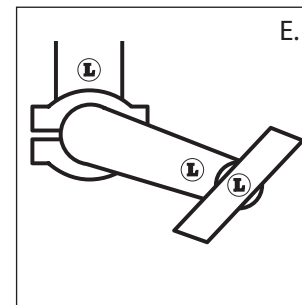
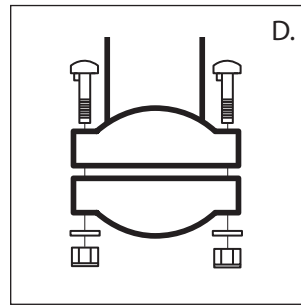
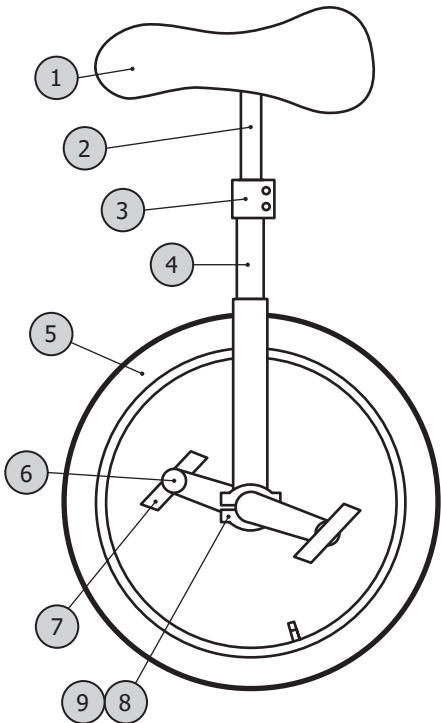

## Things that can go wrong

Unicycles are pretty durable but they do need maintaining, here are things to look out for:

- Loose pedals; normally found when riding or by holding the pedal and wiggle it. Tighten immediately! Check that the wheel is fitted in the frame the correct way around. Riding on loose pedals will destroy the cranks.
- Loose cranks; this is normally characterised by a creaking noise. Tighten the axle bolt immediately! If this is left loose it will destroy the crank and hub and to all intent and purpose the unicycle.
- Loose or tight bearing holder bolts; it is most common to find these too tight and the wheel not spinning correctly. Loosen them to free the wheel, after a few minutes of use check that they are still tight enough to stay on.